

Please read these instructions carefully. Faulty parts which are under warranty should be returned.

## FITTING INSTRUCTIONS - MOTOR.

UKKIT31

1. Remove the battery tray from the motor. This is held in position by four screws and nuts, two either side of the motor (See fig.1). To remove the screws you must prevent the nuts, located on the inside of the tray, from turning. You will notice that these screws pass through two plastic spacers. The spacers are sandwiched between the battery tray and the metal plate on which the motor rests. These spacers must be fitted during re-assembly. Also remove the remaining four screws that hold the motor plate (humped shape piece of metal), remember to re-fit the plate once the new motor is in place.
2. Unplug the two electrical connections to the motor.
3. Attached to the end plate of the motor, opposite the gearbox, is an 'L' shaped bracket holding it to the trolley frame. With the trolley unfolded, remove the screw attaching this bracket to the frame. (See fig.2)
4. Remove the two screws holding the motor to your gearbox. They are at the opposite end to the L shaped bracket.
5. Remove the motor complete with the 'L' bracket from the trolley.
6. Transfer the 'L' bracket to the new motor.
7. Re-assemble the trolley in reverse order.
8. If, once re-assembled, the trolley is a little noisy, you can adjust the gearbox. To do this, lay the trolley on the ground, with the wheels off the ground, then loosen the two screws that hold the gearbox to the motor and apply pressure to the gearbox (with the trolley running). Tighten the two screws when it is running quietly.
9. If, when the trolley is tested, the motor runs but the wheels do not drive, the wires connected to the motor need to be reversed.

NB: Please note that the coupling between the motor and the gearbox has been changed, please replace with the new one supplied.

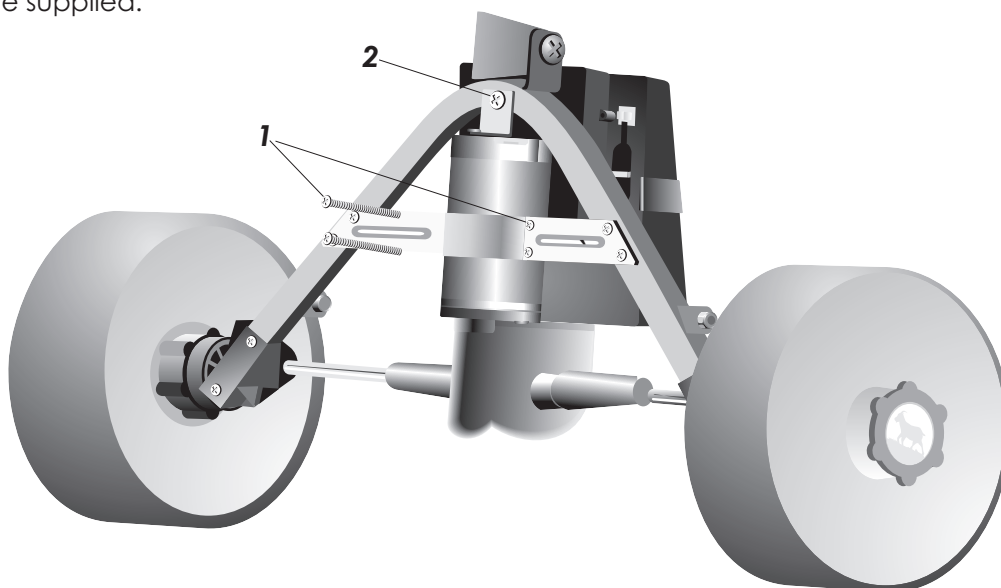

*If you have any queries regarding this procedure please don't hesitate to call and speak to our technical staff.*

### Hill Billy Powered Golf Trolley

PO Box 533 Sittingbourne Kent ME10 9BX England  
Telephone 01795 413830 Fax 01795 413831